



Project Number: 21061
Project Office: Whangarei
Project Manager: S Duncan

CONSENT DRAWINGS

CORKS ROAD TO LAKES DRIVE FOOTPATH

DRAWING INDEX				
SHEET	DESCRIPTION	ISSUE DATE	STATUS	REVISION
1	Existing Site Plan (Provided by Macroventures)	2022-03-14	For Information	A
2	Overall Design Site Plan	2022-11-11	Consent	3
3	Design Site Plan 1	2022-11-11	Consent	3
4	Design Site Plan 2	2022-11-11	Consent	3
5	Footpath Long Section	2022-11-11	Consent	2
6	Earthworks Plan with Flood Extents	2022-11-24	Consent	4
7	Box Culvert Plan and Pavement Details	2022-11-15	Consent	4
8	Box Culvert Cross Sections	2022-11-11	Consent	3

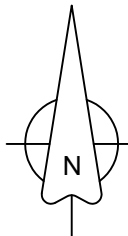
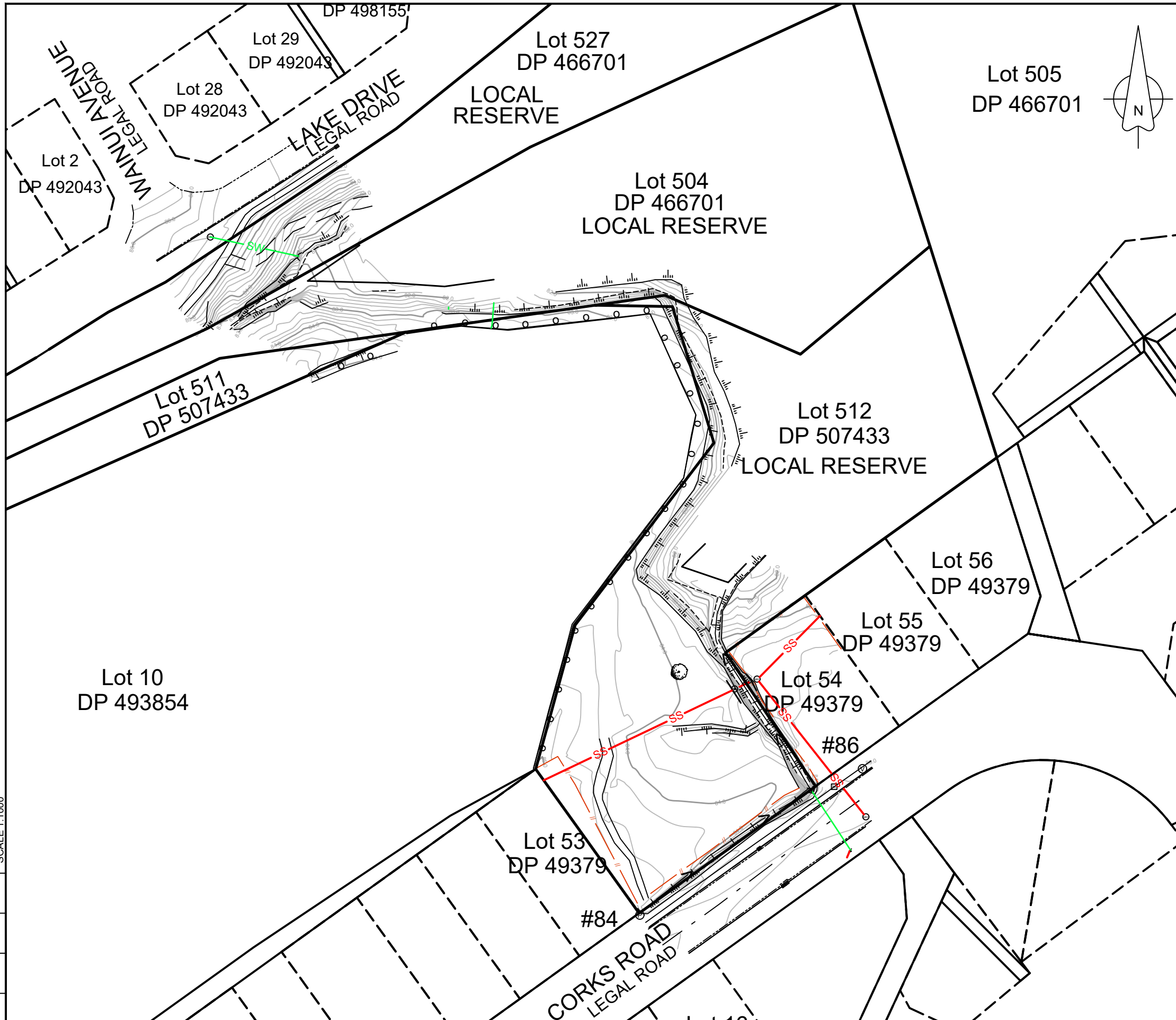

LEGEND	
	CONTOURS MAJOR
	CONTOURS MINOR
	CONTOUR LABELS
	FENCES
	TOP OF BANK
	BOTTOM OF BANK
	CHANNEL OR DRAIN
	PARCEL BOUNDARY
	ABBUTALL BOUNDARY
	RETAINING WALL
	MANHOLES
	FIRE HYDRANT
	WATER VALVE
	CESSPIT / SUMP

NOTES:
 THIS SURVEY HAS BEEN COMPLETED UNDER INSTRUCTION BY THE CLIENT FOR ITS INTENDED PURPOSE. THIS DATA MAY NOT BE SUITABLE FOR OTHER PURPOSES AND THEREFORE WRITTEN AUTHORITY IS NEEDED FROM MACROVENTURES FOR ANY OTHER USE OR REPRODUCTION.

MAJOR CONTOURS ARE AT 1m INTERVALS
 MINOR CONTOURS ARE AT 0.2m INTERVALS
 LOCAL AUTHORITY: WHANGAREI DISTRICT COUNCIL
 COORDINATE SYSTEM: NZGD MT EDEN 2000
 LEVELS DATUM: ONE TREE POINT DATUM 1964
 ORIGIN OF COORDINATES: ALP IV DP 334027
 ORIGIN OF LEVELS: ALP IV DP 334027
 RL= 84.575m

SURVEY DATE: 2ND OF FEBRUARY 2022

DRAINAGE FEATURES DENOTED "INDICATIVE PIPE/MH POSITION FROM WDC GIS" HAVE BEEN SCALED/TAKEN FROM COUNCIL GIS RECORDS AND MUST BE CHECKED PRIOR TO DESIGN AND CONSTRUCTION. AS A RESULT MACROVENTURES ACCEPTS NO LIABILITY FOR THE SERVICES AND THEIR POSITIONS SHOWN OR OMITTED FROM THIS PLANLIABILITY

50
40
30
20
10
0
SCALE 1:1000















REV.	REVISION DETAILS	DRAWN	APP.
C			
B			
A	1ST ISSUE	JL	HC

PROJECT DETAILS	TITLE
84 CORKS ROAD LOT 512 DP 507433, LOT 511 DP 507433, LOT 504 DP 466701 & LOT 527 466701 WHANGAREI DISTRICT COUNCIL	TOPOGRAPHICAL SURVEY PLAN SHEET 1 OF 4

DATE CREATED 10-02-2022	DRAWN JL	DESIGNED -	APPROVED HC
MACRO REF NO P0268-007	SCALE 1:1000 @ A3	STATUS FOR INFORMATION	
DWG NUMBER 007-T01	REVISION A		

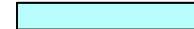
Legend:

-  Lot boundaries
-  1.0m Contour
-  0.2m Contour
-  Proposed footpath
-  Proposed subsoil drainage
-  Existing stormwater
-  Existing wastewater
-  Existing stormwater drain
-  Existing retaining wall
-  Existing roading/footpath
-  1% AEP Flood Hazard (NRC Maps)
-  10% AEP High-Risk Flood Hazard (NRC Maps)
-  Proposed Conduit (location and design to be confirmed)

Notes:

1. Contractor to locate all existing services prior to commencement of construction.
2. Contractor to confirm all dimensions and levels prior to commencement of construction.
3. Council approved erosion and sediment control devices to be installed prior to any earthworks being undertaken.
4. All Ecological Report recommendations are to be adhered to.
5. Power conduit location and pits are indicative only. Design to be carried out by others and to be confirmed at time of tender.

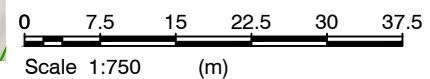
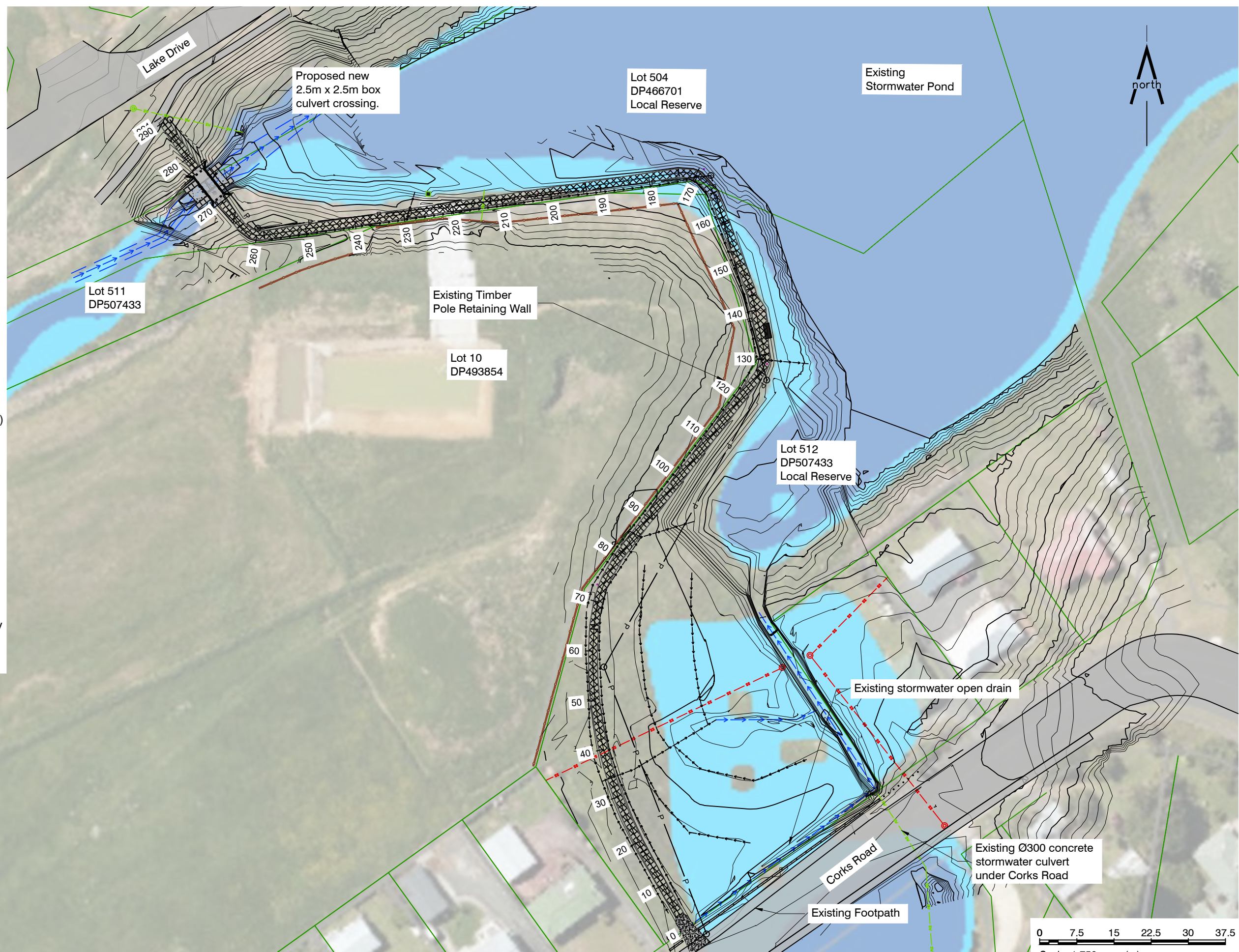

Copyright: LDE Ltd. All rights reserved / Do not scale off drawings / Confirm all dimensions on site prior to work

CLIENT	PROJECT
Northland Transport Alliance	Corks Road to Lake Drive Footpath







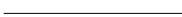

DRAWING TITLE
Overall Design Site Plan

DESIGN:	LR
DRAWN:	LR
DATE:	9.03.22
CHECKED:	SD
SCALE AS:	1:750

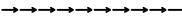
PROJECT STATUS:	Resource Consent
PROJECT:	21061
SHEET:	2 of 8
DRAWING No:	21061-C01
REV:	3

No.	REVISION	BY	DATE
3	Updated and reissued for Consent	SD	11/11/2022
2	Updated and issued for consent	SD	08/30/2022
1	Issued for consent	LR	18/03/22
0	Issued for comment	LR	9/03/22

Legend:

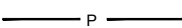
-  Lot boundaries
-  1.0m Contour
-  0.2m Contour
-  Proposed footpath
-  Proposed subsoil drainage
-  Existing stormwater
-  Existing wastewater
-  Existing open drain
-  Existing retaining wall
-  Existing footpath
-  Proposed Conduit (location and design to be confirmed)

Notes:

1. Contractor to locate all existing services prior to commencement of construction.
2. Contractor to confirm all dimensions and levels prior to commencement of construction.
3. Council approved erosion and sediment control devices to be installed before any earthworks are undertaken.
4. All Ecological Report recommendations are to be adhered to.
5. Power conduit location and pits are indicative only. Design to be carried out by others and to be confirmed at time of tender.

Tie new footpath into existing footpath and install name blade sign. Signage to state "Walkway to Corks Road" and be installed in accordance with WDC requirements.

New 2.5m x 2.5m box culvert. Refer to culvert cross-section and long-section for details.

Proposed 1.8m wide concrete footpath with crossfall between approx. CH260 - CH281.

Existing outlet point for Ø600 dia SW pipe with rip rap protection.

2x Ten4 fabricated galvanised steel bollards at each end of culvert crossing. Location and offsets to be confirmed on site.

Existing Ø150mm SW pipe. Approximately 300mm above existing ground level. Length of pipe that crosses walkway to be lowered using 90° bend and buried minimum 600mm below proposed walkway level. Refer to Typical Details.

Proposed 1.8m wide concrete path.

Location of new 3.0m by 1.2m platform for seat. Platform and seat design by others.

Maintain minimum 600mm gap between existing timber pole retaining wall or boundary and proposed footpath

Maintain minimum 600mm gap between existing timber pole retaining wall or boundary and proposed footpath

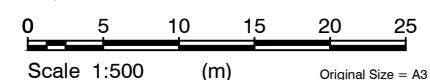

Copyright: LDE Ltd. All rights reserved / Do not scale off drawings / Confirm all dimensions on site prior to work

CLIENT Northland Transport Alliance	PROJECT Corks Road to Lake Drive Footpath	DRAWING TITLE Design Site Plan 1		<table border="1" style="width: 100%; border-collapse: collapse;"> <tr> <td>DESIGN:</td> <td>LR</td> <td>PROJECT STATUS:</td> <td>Resource Consent</td> </tr> <tr> <td>DRAWN:</td> <td>LR</td> <td>PROJECT:</td> <td>21061</td> </tr> <tr> <td>DATE:</td> <td>9.03.22</td> <td>SHEET:</td> <td>3 of 8</td> </tr> <tr> <td>CHECKED:</td> <td>SD</td> <td>DRAWING No.:</td> <td>21061-C02</td> </tr> <tr> <td>SCALE AS:</td> <td>1:500</td> <td>REV.:</td> <td>3</td> </tr> </table>	DESIGN:	LR	PROJECT STATUS:	Resource Consent	DRAWN:	LR	PROJECT:	21061	DATE:	9.03.22	SHEET:	3 of 8	CHECKED:	SD	DRAWING No.:	21061-C02	SCALE AS:	1:500	REV.:	3
DESIGN:	LR	PROJECT STATUS:	Resource Consent																					
DRAWN:	LR	PROJECT:	21061																					
DATE:	9.03.22	SHEET:	3 of 8																					
CHECKED:	SD	DRAWING No.:	21061-C02																					
SCALE AS:	1:500	REV.:	3																					

Legend:

- Lot boundaries
- 1.0m Contour
- 0.2m Contour
- Proposed footpath
- - - - - Proposed subsoil drainage
- - - - - Existing stormwater
- - - - - Existing wastewater
- - - - - Existing open drain
- Existing retaining wall
- Existing footpath
- p — Proposed Conduit (location and design to be confirmed)

Notes:

1. Contractor to locate all existing services prior to commencement of construction.
2. Contractor to confirm all dimensions and levels prior to commencement of construction.
3. Council approved erosion and sediment control devices to be installed before any earthworks are undertaken.
4. All Ecological Report recommendations are to be adhered.
5. Power conduit location and pits are indicative only. Design to be carried out by others and to be confirmed at time of tender.

Maintain minimum 600mm gap between existing timber pole retaining wall or boundary and proposed footpath

Existing timber pole retaining wall

Subsoil drainage to be installed on upslope side of walkway from CH05 to CH260. Drain to discharge to existing overland flowpaths as shown. Refer to Typical Details.

Subsoil drainage to be installed on downslope side of walkway from CH05 to CH90. Drain to discharge to existing overland flowpaths as shown.

Install new residential street sign at entrance to walkway as per WDC EES Sheet 24. Street sign to read "Walkway to Lake Drive".

New 1.8m wide concrete path.

Conduit Pit
Approx. 10m offset

Subsoil drains to be installed along contours of site at 10m intervals. Drain to existing overland flowpath as shown.

Approx. 10m offset

Install 1x removable 150 x 150 H4 timber bollard at center of entrance to walkway. As per WDC EES Sheet 58.

Install new non-removable 125 x 125 H4 timber bollards set in 300mm deep concrete at maximum 1.4m centers for length of boundary. Bollards to extend 600mm above ground. 75mm thick concrete mowing strip along full length of bollards. Mowing strip to extend 100mm each side of bollards.

Existing stormwater open drain to be cleaned out and renewed. Depth to be increased to minimum of 150mm with side slopes of 1 in 5. Refer to Typical Details.

Install new residential vehicle crossing at entrance to walkway. Crossing details to be as per WDC EES Sheet 18. Walkway to be 2.7m width for first 2m within property boundary before reducing to 1.8m wide. Install accessible pedestrian crossing as per WDC EES Sheet 17 southern side of Corks Road directly opposite walkway entrance.

Install accessible pedestrian crossing as per WDC EES Sheet 17 southern side of Corks Road directly opposite walkway entrance.

Scale 1:500 (m) Original Size = A3

Copyright: LDE Ltd. All rights reserved / Do not scale off drawings / Confirm all dimensions on site prior to work

CLIENT Northland Transport Alliance	PROJECT Corks Road to Lake Drive Footpath	DRAWING TITLE Design Site Plan 2		DESIGN: LR DRAWN: LR DATE: 9.03.22 CHECKED: SD SCALE A3: 1:500	PROJECT STATUS: Resource Consent PROJECT: 21061 SHEET: 4 of 8 DRAWING No.: 21061-C03 REV: 3
REVISION					
No.	REVISION	BY	DATE		
3	Updated and reissued for consent	SD	11/11/2022		
2	Updated and issued for consent	SD	30/08/2022		
1	Issued for consent	LR	18/03/22		
0	Issued for comment	LR	09/03/22		

Notes:

1. Locations and extents of structures shown in section are approximate only and to be confirmed onsite with the Engineer.
2. Footpath to be constructed to follow existing contours.
3. Longitudinal grade not to exceed 12.5%.

Existing Ø150mm SW pipe. Approximately 300mm above existing ground level. Length of pipe that crosses walkway to be lowered using 90° bend and buried minimum 600mm below proposed walkway level.

Existing Ø600mm SW pipe. Depth unknown. Contractor to confirm location and depth on site prior to beginning works.

Proposed new 2.5m by 2.5m Box Culvert.

Datum 75.0

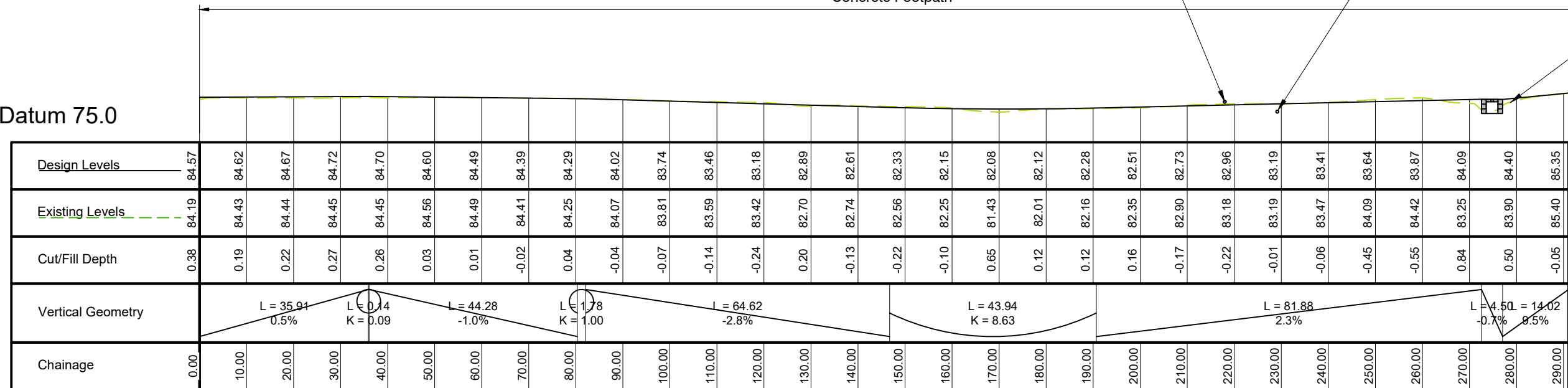











PROPOSED FOOTPATH Long Section

Scale: Horizontal 1:1000, Vertical 1:1000

CLIENT Northland Transport Alliance	PROJECT Corks to Lake Road Footpath	DRAWING TITLE Footpath Long Section		DESIGN: LR	PROJECT STATUS: Resource Consent
				DRAWN: LR	PROJECT: 21061
				DATE: 14.03.22	SHEET: 5 of 8
				CHECKED: SD	DRAWING No: 21061-C04
				SCALE A3: 1:500	REV: 2
				2 Updated and reissued for consent 1 Updated and issued for consent 0 Issued for consent	

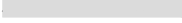
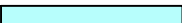
Legend:

-  Lot boundaries
-  1.0m Contour
-  0.2m Contour
-  Proposed footpath
-  Existing stormwater
-  Existing wastewater
-  Existing stormwater drain
-  Existing retaining wall
-  Existing footpath
-  Silt fence
-  1% AEP Flood Hazard (NRC Maps)
-  10% AEP Flood Hazard (NRC Maps)

Notes:

1. Contractor to locate all existing services prior to commencement of construction.
2. Contractor to confirm all dimensions and levels prior to commencement of construction.
3. Council approved erosion and sediment control devices to be installed prior to any earthworks being undertaken.
4. Erosion and sediment control measures to be installed in accordance with Auckland Councils GD05 or relevant WDC/NRC Standards.
5. Stockpile top soil onsite for reuse.

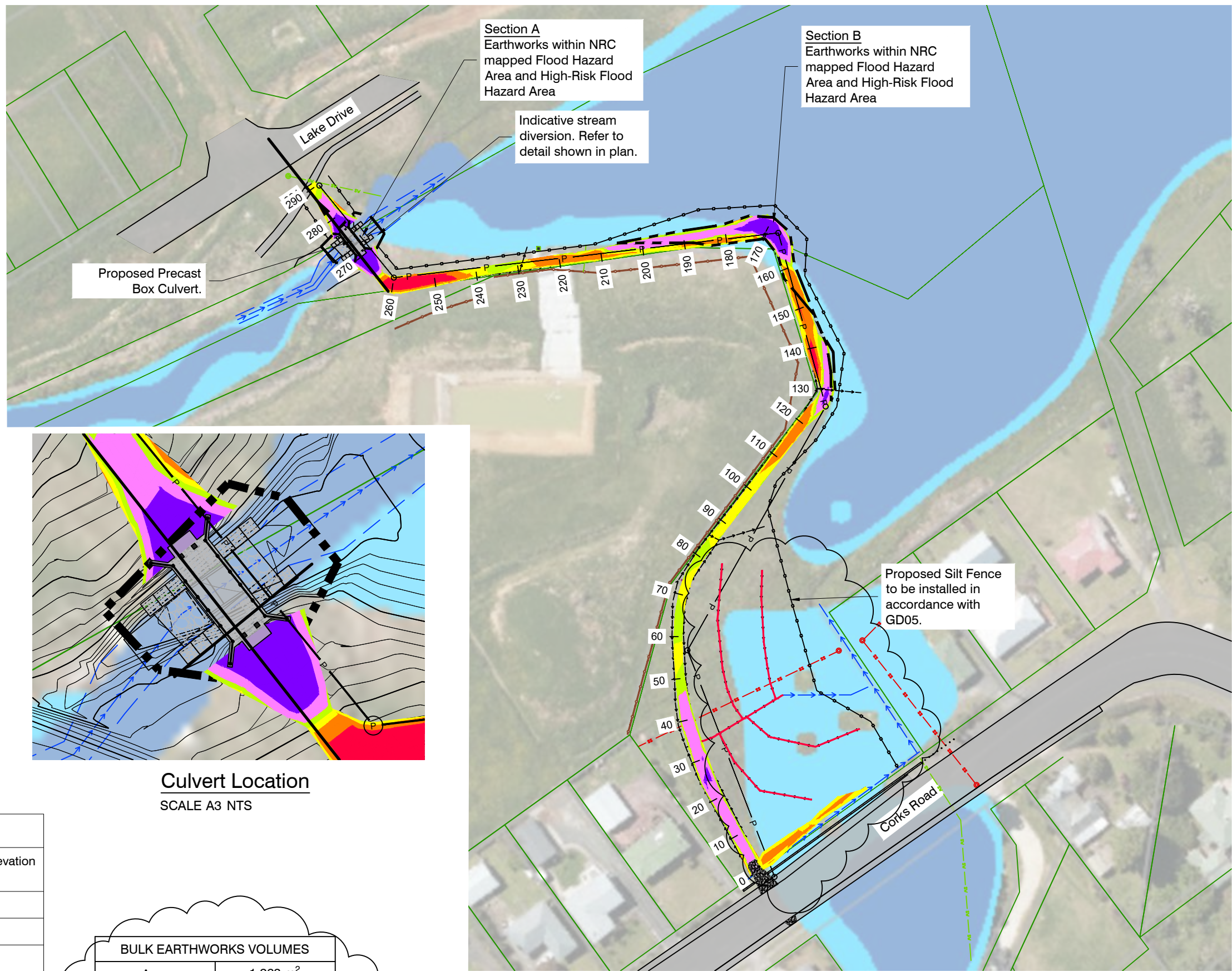

Culvert Location
SCALE A3 NTS

Surface Analysis: Elevation Ranges

Number	Color	Minimum Elevation (m)	Maximum Elevation (m)
1	Red	-0.900	-0.300
2	Orange	-0.300	-0.100
3	Yellow	-0.100	0.000
4	Light Green	0.000	0.100
5	Pink	0.100	0.300
6	Purple	0.300	2.300

BULK EARTHWORKS VOLUMES

Area	1,263 m ²
Cut	152m ³
Fill	174 m ³
Net (Fill)	22 m ³

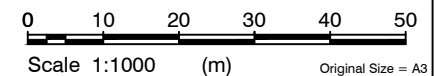

Copyright: LDE Ltd. All rights reserved / Do not scale off drawings / Confirm all dimensions on site prior to work

CLIENT	PROJECT
Northland Transport Alliance	Corks Road to Lake Drive Footpath

DRAWING TITLE
Earthworks Plan with Flood Extents

DESIGN:	LR
DRAWN:	LR
DATE:	09.03.22
CHECKED:	SD
SCALE A3:	1:1000



PROJECT STATUS:	Resource Consent
PROJECT:	21061
SHEET:	6 of 8
DRAWING No:	21061-C05
REV:	4

No.	REVISION	BY	DATE
4	Earthworks area and volumes updated	SD	24/11/2022
3	Updated and reissued for consent	SD	11/11/2022
2	Updated and issued for consent	SD	30/08/2022
1	Issued for Consent	LR	18/03/22
0	Issued for comment	LR	09/03/22

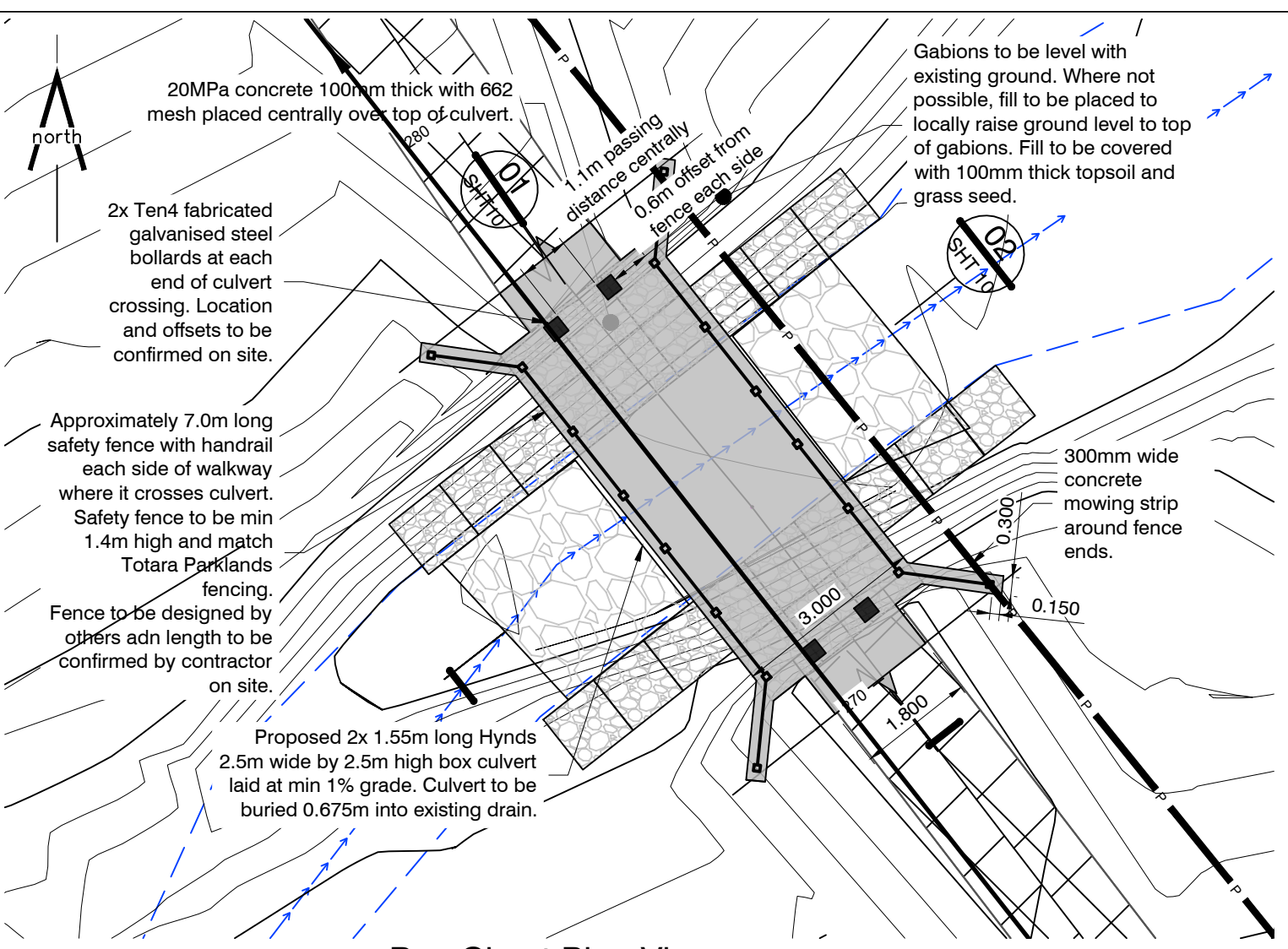

Box Culvert Plan View
1:100

- Notes:
1. Construction to be carried out in dry conditions only.
 2. Control joints (transverse) to be at maximum 2m intervals. Saw cut joints, if used, are to be to a depth of 1/3 of the thickness of the footpath. Saw cuts are to be made no later than two days after the concrete has been cast.
 3. In order to prevent trips/falls - there must be no lips/steps greater than 5mm at slab joints.
 4. Max cut slope to be 1 in 2. Max fill slope to be 1 in 3.

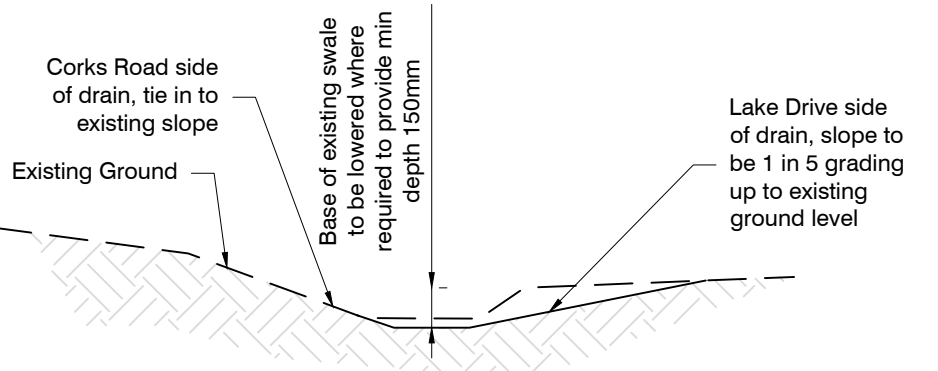
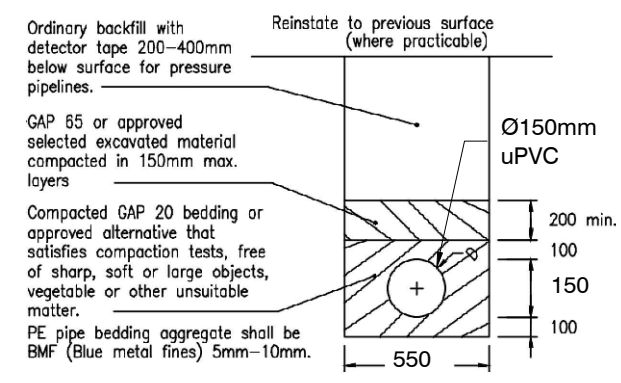
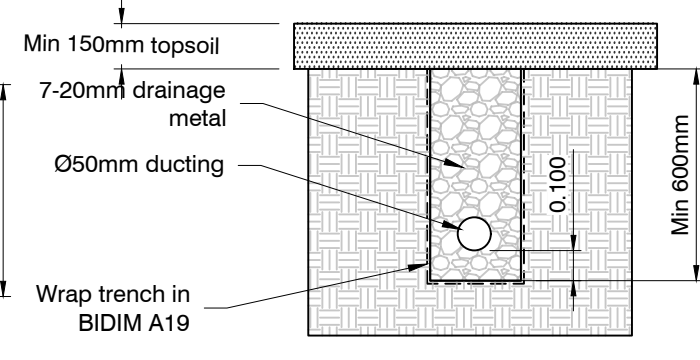
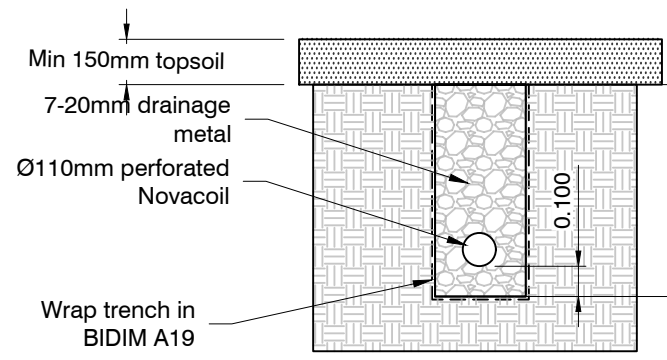
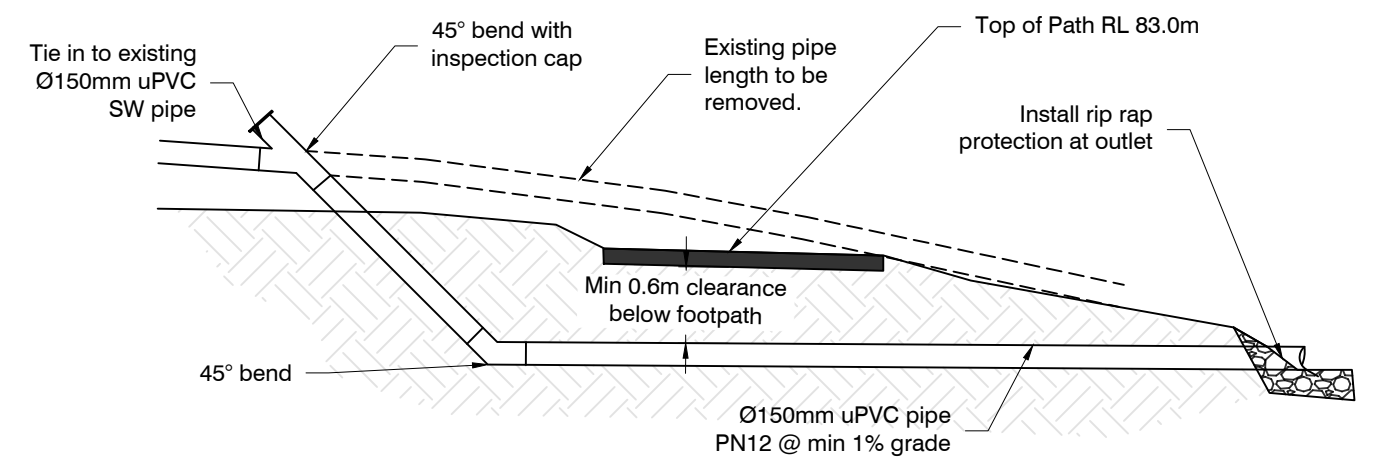
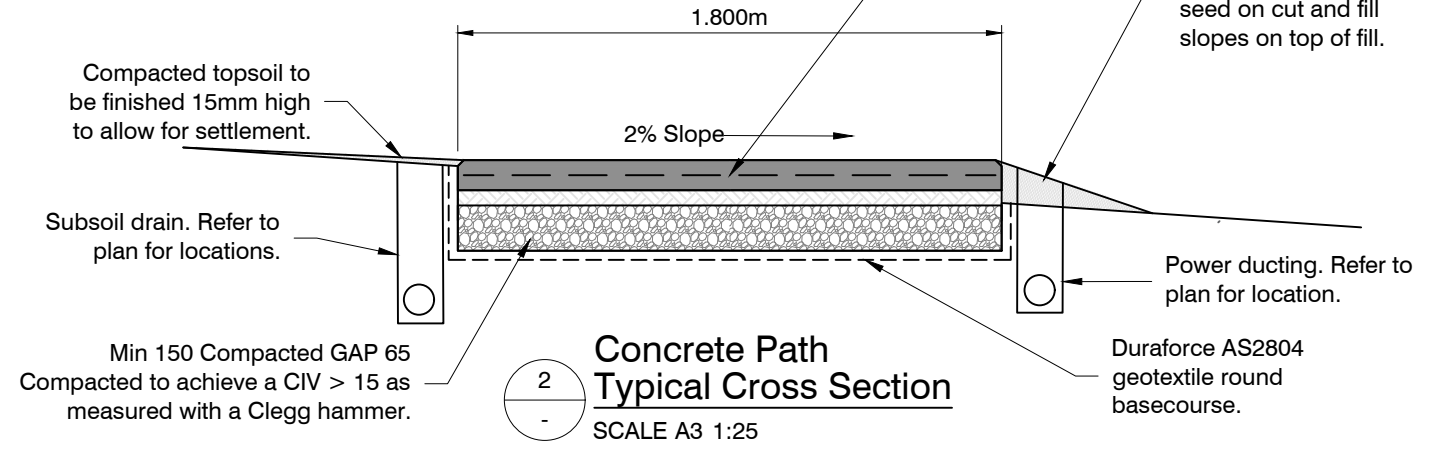

- Notes:
1. Minimum 150mm vertical clearance from services and subsoil drains. Ducting to be laid higher than services and subsoil drains.
 2. Where services and subsoil drains run parallel, minimum horizontal clearance to be 300mm.

Copyright: LDE Ltd. All rights reserved / Do not scale off drawings / Confirm all dimensions on site prior to work

CLIENT Northland Transport Alliance	PROJECT Corks Road to Lake Drive Footpath	DRAWING TITLE Box Culvert Plan and Typical Details	DESIGN: LR	PROJECT STATUS: Resource Consent
			DRAWN: LR	PROJECT: 21061
			DATE: 09.03.22	SHEET: 7 of 8
			CHECKED: SD	DRAWING No: 21061-C06
			SCALE A3: As shown	REV: 4

Hand rail design by others. Hand rail to be min 1.4m high Boundaryline Durapanel or similar to match Totara Parklands fencing. Details to be confirmed at time of tender.

1m x 1m x 0.5m gabion baskets on top of culvert. All gabion baskets to be appropriately fastened together.

1m x 1m x 1m gabion baskets at sides of culvert. All gabion baskets to be appropriately fastened together.

Proposed 2.5m high by 2.5m wide Box Culvert to be installed in accordance with the manufacturers recommendations. Culvert to be buried 0.675m below existing channel bed.

GAP 65 300mm thick compaction to achieve min 25 CIV. Subgrade > 100kPa.

20MPa concrete 100mm thick over top of culvert. 662 mesh placed centrally.

Granular fill compacted in layers no thicker that 150mm

Extent of excavation

Granular fill compacted in layers no thicker that 150mm

Install 100mm rock. 2 layers thick. 200mm thick total.

SECTION 01
SHT 10
1:50

Hand rail design by others. Hand rail to be min 1.4m high Boundaryline Durapanel or similar to match Totara Parklands fencing. Details to be confirmed at time of tender. Maximum 0.25m from edge of concrete.

Proposed 2.5m by 2.5m Box Culvert as approved by the Engineer to be installed in accordance with the manufacturers recommendations. Box culvert length to be 3.1m (use 2x 1.55m long typical culvert sections).

Existing top of bank

Stream flow

GAP 65 300mm thick compaction to achieve min 25 CIV. Subgrade > 100kPa.

Install 100mm rock. 2 layers thick.

0.675m embedment

Existing ground

1m x 1m x 0.5m gabion baskets as headwall on culvert. GAP65 to be used as fill along center of footpath.

1m x 1m x 1m gabion baskets along channel

Stream flow

Channel lowered 680mm at 1 in 3 grade over 2m length

2x 1.55m long sections of box culvert 3.10m total length
5.2m channel at RL 81.12m

Channel lowered 680mm at 1 in 3 grade over 2m length

SECTION 02
SHT 11
1:50

Gabion Basket Notes:

1. Gabion basket sizes to be as shown on drawings.
2. Gabion basket fixings to be as per the manufacturers requirements.
3. Approximate number of gabion baskets:
1m x 1m x 1m = 41
1m x 1m x 0.5m = 14
(Contractor to confirm required number on site).

Box Culvert Notes:

1. Box culvert to have internal dimensions 2.5m high x 2.5m wide.
2. Required no. of typical 1.55m long box culvert sections = 2.
3. Bolting and grout required to be as per the box culvert manufacturer's specifications. If no specifications provided,
4. Loading on culvert to be pedestrian traffic only. Not intended to be accessible to motorised vehicles.
5. Wall thickness to be as per the manufacturer's recommendations.

CLIENT	PROJECT	DRAWING TITLE
Northland Transport Alliance	Corks to Lake Road Footpath	Box Culvert Cross Section

DESIGN: LR	PROJECT STATUS: Resource Consent
DRAWN: LR	PROJECT: 21061
DATE: 09.03.22	SHEET: 8 of 8
CHECKED: SD	DRAWING No: 21061-C07
SCALE A3: 1:25	REV: 3

No.	REVISION	BY	DATE
3	Updated and reissued for consent	SD	11/11/2022
2	Updated and issued for consent	SD	30/08/2022
1	Issued for consent	LR	18/03/22
0	Issued for comment	LR	9/03/22

